

Automatic dosing of 30 samples

A walkaway solution



The Autosampler QS30 powder dosing system doses up to 30 samples accurately and automatically. It is based on the core competences of QUANTOS: simple operation, fast powder dosing and protection for employees and dosed substances.

Features of the Autosampler QS30

- Automated handling of 30 samples
- Closed system under acrylic cover
- Small footprint
- Various powder dosing quantities
- Suitable for various sample vessels
- QH250-L dosing head for up to 250 doses
- Easy to replace magazines
- Effortless to clean

Benefit from time savings and process reliability

Thanks to the QS30 dosing system, you can process up to 30 samples in a fully automated manner. You will save time, that you can then devote to other tasks. The space-saving, ring-shaped design fits into the tightest of laboratory spaces.

You can prepare the numbered cassettes, and exchange them at your convenience. The acrylic tunnel prevents contamination of the substance from the external environment - while employees and the environment are protected against potentially harmful substances. In this closed system, the QS30 weighs in fast dosing cycles due to the elimination of air flow, so the balance stabilises faster.

Thanks to the wide range of accessories, you can execute all common powder dosing applications. Alongside the tried and tested QH025-B (25 doses) and QH075-B (75 doses) dosing heads, the new QH250-L is now available to purchase and can be used for 250 doses. Vial adapters suit small bottles with \varnothing 10.3 - 21 mm and larger vessels with \varnothing 24 mm and 28 mm.



30 precise doses

Up to 30 samples can be prepared per run. Simply enter a target quantity per sample on the terminal of the QS30 dosing system.



Closed system

The sample vessels and your substances are protected by an acrylic tunnel. The dosing process takes place in a closed system, which in turn also protects the user.

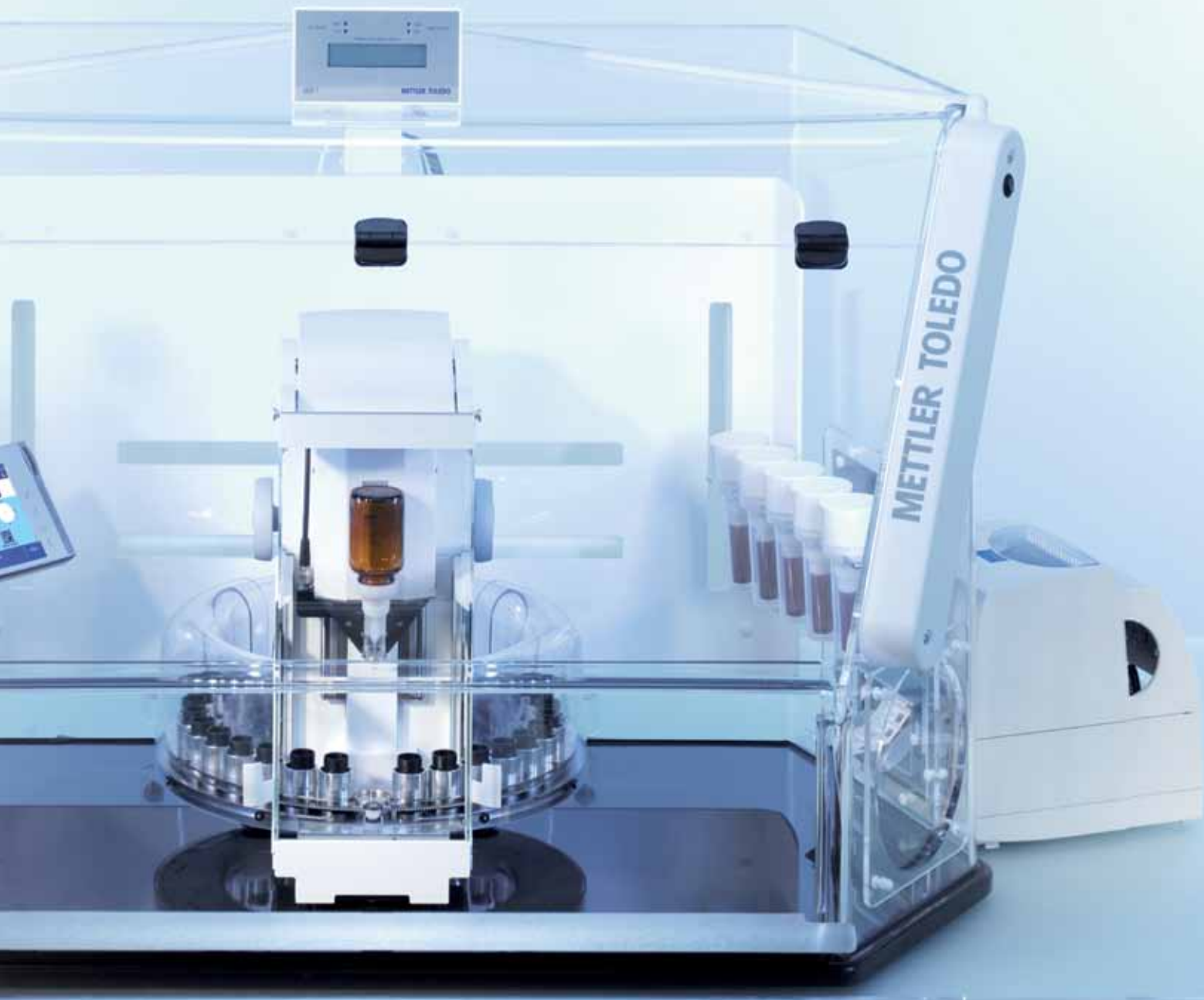

Cassettes for 5 vessels

Prepare the numbered cassettes with additional vessels spare set and save even more time: Simply exchange the cassettes after dosing and continue with your work.



250 doses per unit

The QH250-L dosing head is the perfect complement to the Autosampler. With 250 doses and a capacity of 120 ml, it is ideally suited to larger sample preparations.



Various sample vessels

Fill a variety of sample vessels with an outer diameter of 10.3 – 28.0 mm.



Work efficiently

Increase your efficiency: Automate your daily routine and give other tasks your undivided attention.

QS30 specifications

Dimensions (width x depth x height)	430.5 x 473.0 x 496.0 mm
Number of sample vessels	max. 30
Diameter of sample vessel	max. 28 mm
Opening of the sample vessel	min. 8 mm
Height of the sample vessel	max. 115 mm
Vial adapter for ErgoDisc	Ø 10.3 mm, 12.0 mm, 15.0 mm, 16.2 mm, 21.0 mm
Cassettes for sample vessel, 5 bottles	Ø 24.0 mm, 28.0 mm



1	Rotatable cassette carrier (ring)
2	Numbered cassette for 5 sample vessels (total of 6 cassettes for a total of 30 sample vessels)
3	Sample vessel
4	Tunnel (acrylic glass) with right side door
5	Tunnel (acrylic glass) with left side door
6	Door handle
7	Front door
8	Rear cover (acrylic glass)
9	Weighing pan

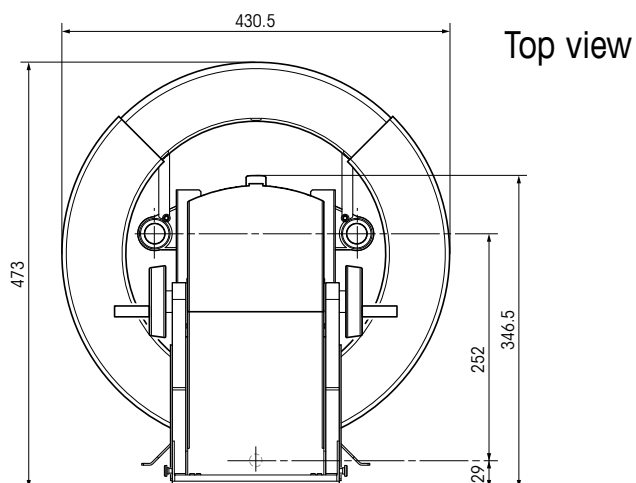
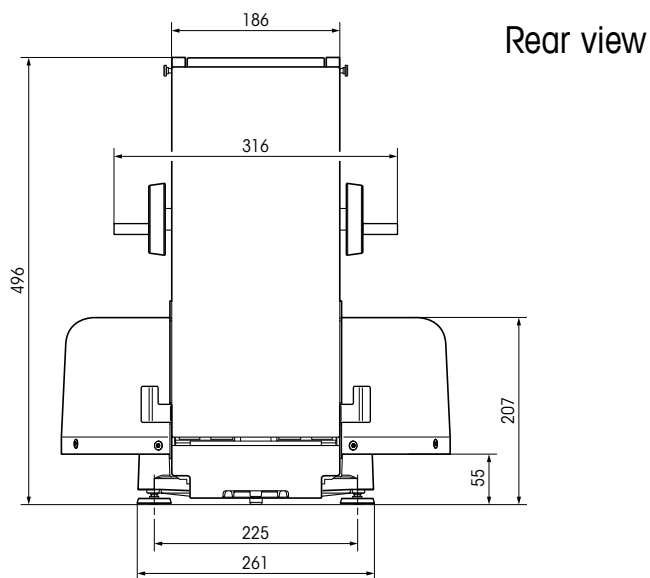

www.mt.com/quantos

For further information



Mettler-Toledo AG
 Laboratory & Weighing Technologies
 CH-8606 Greifensee, Switzerland
 Tel. +41 44 944 22 11
 Fax +41 44 944 30 60

Subject to technical changes
 © 07/2009 Mettler-Toledo AG
 Printed in Switzerland 11796343